



FRANKLIN

CABLE LAID

SLINGS



FRANKLIN OFFSHORE





# LIFT SPE

## Franklin Offshore A world-class company with a global reach

Franklin Offshore is headquartered in Singapore, serving the marine oil & gas and offshore construction industry. Our companies are strategically located in Singapore, Australia, Indonesia, South Korea, Azerbaijan, Qatar, United States of America and the Netherlands. We have an experienced and dedicated workforce and a corporate culture that is solidly based on the principles of professionalism, innovation and service.



Waterfront Operations Base in Singapore

### Our products and services

The Franklin Offshore group of companies is a leading provider of steel wire rope, rigging and mooring equipment. Expertise includes manufacturing of cable laid slings, Flemish Lock slings, inspection and load testing services. The company provides high quality integrated solutions in temporary and permanent mooring projects including a comprehensive range of 'OIC' services.



Manufacturing  
Franklin Cable Laid Slings

### Heavy-Lift Slings for the Offshore Construction Industry

Our expertise includes the manufacture of heavy-lift cable laid slings, Flemish Lock slings, inspection, and load-testing services.

### Franklin – The Brand for Quality

Franklin Offshore manufactures excellent products and provides a full spectrum of value-added services. We give such products or services developed by our group, the Franklin brand name.

# CIALISTS

## Our Beliefs

Franklin Offshore is a business driven by the passion and know-how of our people. Thus, we treat them with the care and respect they deserve. Our people are our most important assets.

### Safety takes Priority

Safety takes priority and nowhere is safety more important than in the manufacture, supply, handling, inspection and installation of cable laid slings.



Take: 8 Safety and Health Awareness Campaign

### HSE MS Health Safety Environment Management System

In all our operations, it's our commitment to pursue the highest possible standards to maximize our Health, Safety and Environmental performance. It's our commitment:

- Making Safety, Health and Environmental considerations a top priority.
- Conducting our business in a manner consistent with the Safety and Health considerations of our employees and customers while protecting the Environment.
- Developing and implementing training and procedures to reduce incidents and accidents and continually improve our HSE Health Safety Environment Management Systems.

Franklin Offshore also has earned the prestigious Bizsafe Star award from the



Workplace Safety and Health Council in Singapore. 'Bizsafe Star' accreditation permits us to provide products and services to Singapore's shipbuilding and construction industries.



Our commitment is demonstrated by our investment. Dedicated QA/QC/HSE MS Management approvals



## Franklin Offshore — we're always reaching higher

We think that the ongoing quest for excellence is what separates the winners in life from the 'also-rans.'

To us, it is one of the defining characteristics of leadership.

In 1993, we decided to pursue a world's record. On our first attempt, we were honoured to be added to the list of Guinness World Record holders for having created 'The largest diameter cable laid rope' in the world.

Then, in 2003, our team set another new Guinness World Record; this time for constructing 'the longest cable laid steel wire rope grommet sling.'

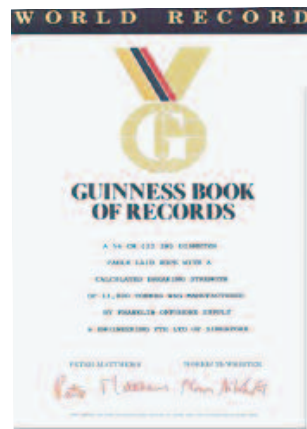

Franklin riggers with the World-Record-Holding grommet sling



## The Heaviest Lift In West Africa

The Exxon Mobil 11,650-tonne YOHO deck module. The lift was carried out by Saipem S 7000 in West Africa using Franklin Cable Laid Slings.

Each of the four slings was 358-mm in diameter and over 88-metres in length with a calculated sling breaking load (CSBL) of 4,317-tonnes.



Franklin riggers make light work of heavy-lift slings



# Franklin Offshore— Leadership through innovation

We have always prided ourselves on being an innovation company rather than being just a regular company.

Thus, we have acquired patents for our unique manufacturing processes of cable laid slings that lead the industry.

Our proprietary large-diameter rope handling equipment helps us meet the ever-increasing demands for consistent, high quality heavy-duty cable laid slings. This cutting-edge technology includes 360-degree rotating vice and sling coiling machines.



Patent certificates for our proprietary method of manufacturing wire rope, and for our proprietary method of producing both rope and cable laid wire rope grommets

Our equipment and expertise allow us to manufacture heavy-lift cable laid slings in matched sets where the quality and strength are consistent— which is an essential requirement in mission-critical lifting projects.

## Franklin Offshore— Areas of special expertise

- Manufacture
- Inspection
- Certification
- Storage
- Delivery
- Installation
- Refurbishment





# ATORS

## There's no substitute for quality

We are meticulous about adhering to our Quality Control Plan (QCP) to manufacture, certify, and deliver only the highest possible quality.

Experienced staff, specific work instructions, manufacturing and inspection processes (including client-driven requirements) are encompassed in our QCP.



Franklin Offshore Europe BV is the Franklin Cable Laid Centre in Europe



Clients' slings for refurbishment

Included in our QCP, all equipment is certified fit for use through our stringent Inspection, Test and Certification (ITC) system. Then, meticulous sling coiling and equipment packing operations are performed and our products are delivered worldwide.

## Franklin Cable Laid Sling Table

Reference: IMCA M 179 Hand Spliced Soft Eyes Each End		Table Reference: MCLT/01 Rev. 0
Sling Diameter / mm	CRBL	CSBL / MBL
168	1360	1020
176	1378	1033
180	1516	1137
183	1540	1155
187	1678	1258
195	1703	1278
199	1841	1381
208	2016	1512
211	2044	1533
218	2197	1648
222	2280	1710
231	2418	1814
235	2587	1940
241	2616	1962
250	3222	2417
256	3074	2306
262	3122	2342
270	3301	2475
283	4041	3031
301	4450	3337
321	4878	3659
358	5754	4315
379	6351	4763
385	6440	4830
418	7225	5419
424	7320	5490

The calculations within the tables are given for reference only as a general guide. Contact our sales engineers for further information.

**SMEN**

## Franklin Grommet Slings

Franklin Cable Laid Grommet Table	
Reference: IMCA M 179 Table Reference: MCLT/01 Rev.0	
Sling Diameter / mm	CGBL
156	2009
162	2254
168	2285
174	2519
180	2795
186	2795
192	3070
201	3366
213	3672
222	3998
231	4335
240	4672
249	5029
261	5386
270	5743
288	6528
309	7242
327	7956
345	8160
366	9486
384	10200
405	12077
423	13138
444	14239
462	15382



# BIGGER IS

## FRANKLIN FLEMISH LOCK® Cable Laid Slings

FLEMISH LOCK provides 100% termination efficiency compared to 75% with conventional hand-spliced cable laid slings.

To lift today's mega-structures within the offshore construction industry, technically advanced alternative methods of manufacturing heavy lift capacity slings are required.

FRANKLIN FLEMISH LOCK cable laid slings have technical advantages which include no reduction on the termination efficiency.

By specialised methods in producing Franklin Flemish Lock terminations, our cable laid slings have superior lifting capacity.



A FRANKLIN FLEMISH LOCK sling



# BETTER

## FRANKLIN FLEMISH LOCK Cable Laid Sling Table

Table Reference: MCLT/01 Rev.0	
Sling Diameter / mm	CSBL / MBL Tonne
150	1139
152	1148
156	1153
158	1167
162	1286
164	1310
168	1440

**FLEMISH LOCK Cable Laid Slings**  
Significant technical advantages and benefits

- Improved rope load distribution due to termination method and sling design
- Substantial increased sling lifting capacity
- Fixed sling measurement, never moves and no awkward rope tails
- Simplicity in sling length reduction
- Ease of handling and installation
- Slings of shorter length can be produced as no hand splicing is required
- Anti-fouling, robust steel sleeve withstands substantial abuse
- The stretch and movement of the eye and termination are reduced because there are no splicing tucks which will pull down under load

# SAFETY IN

## FLEMISH LOCK Cable Laid Slings

The safety of a FLEMISH LOCK cable laid sling relies on the selection of quality



materials, technical experience and strict manufacturing processes. The craftsmanship and skills required in making such a heavy lift sling is the

result of years of experience, extensive product testing and achievement of positive results.



---

### Product Warning

MAKLOCK was designed specifically to meet the needs of securing the sleeves that are applied to the tails of a Flemish Eye termination of cable laid slings.

The product is unique, approved by Lloyd's Register and must only be used for the purpose for which it was designed. It must not be used for socketing. Wirelock must not be used as a substitute for MAKLOCK.

# EVERY LIFT

## No shortcuts

Franklin Offshore is a registered member of the International Marine Contractors Association (IMCA), the international trade association representing offshore, marine and underwater engineering companies.



IMCA promotes quality, health, safety, and environmental and technical standards with its guidance notes and codes of practice.

Franklin Offshore manufactures FRANKLIN cable laid slings in full compliance with IMCA M 179 Guidance on the Safe Use of Cable Laid Slings and Grommets.

### IMCA M 179 Cable Laid Rope and Sling Ratings:

- Calculated Cable Laid Rope Breaking Load (CRBL) is equal to the sum of the minimum breaking loads of the individual outer and core unit ropes, multiplied by a spinning loss coefficient of 0.85. This is known as the CRBL.
- Calculated Sling Breaking Load (CSBL) For cable laid slings, the CRBL result is multiplied by a Termination Efficiency (ET), which for hand spliced terminations is 0.75. The result is the cable laid sling CSBL.
- Calculated Grommet Breaking Load (CGBL) The calculated minimum breaking load of a Cable Laid Grommet Sling is equal to 12 times the minimum breaking load of the unit rope, multiplied by a spinning loss coefficient of 0.85. The result is the CGBL.



FRANKLIN FLEMISH LOCK slings lifting 1,800-tonne test lift

# PERFECT

## Franklin Testing and Inspection Services

Franklin testing provides a comprehensive tensile testing service which meets or exceeds international standards. Qualified and experienced staff ensure that all testing is carried out to the highest possible professional standard.

### Franklin 2,300-tonne Hydraulic Test Bed

Franklin Test Bed key features include:

- Test bed length: 210 ft
- Bed width: 96 inches
- Tension pull cylinder: 300 Tonne
- Cylinder stroke: 145 inches
- Main pull capacity: 2,300 Tonne
- Cylinder stroke: 44 inches
- Cylinder travel speed: 10 inches per minute

Proof Load Testing Services include:

- All types of steel wire rope slings
- Shackles, tri-plates
- Spreader bars

Test bed is calibrated by DNV



Franklin 2,300 Tonne Hydraulic Test Bed

## Classification Societies

We can arrange directly with any of these classification companies to be onsite and carry out a review of our quality production plans or witness load testing and issue the relevant reports and test certificates:

- ABS
- DNV
- Noble Denton
- Veritas
- Lloyd's Register

# IONISTS

## Franklin Cable Laid Sling - Additional Services

We have gained through years of experience the knowledge to provide a full range of value-added services. We value our expertise in which we can provide integrated heavy-lift solutions.

- Inspection to fulfil specific cable laid sling inspection criteria
- Refurbishment, cleaning, and replacement of sling seizings
- Measurement of the sling under tensile load
- Internal and external lubrication services
- Re-certification, complete with third-party classification society certificates
- Shortening of the sling's effective working length and re-splicing
- Coiling and banding to specific client requirements
- Storing and logistic support
- Onsite technical problem solving
- Onsite sling installation services



Sling splicing service

### Cable Laid Sling Installation Services

High-value cable laid slings need to be handled and installed correctly. We have the ability and experienced personnel to carry out this work onsite. This ensures that your slings are installed correctly and without damage or twists. Comprehensive installation reports are issued, complete with digital photos and a sling visual examination report.

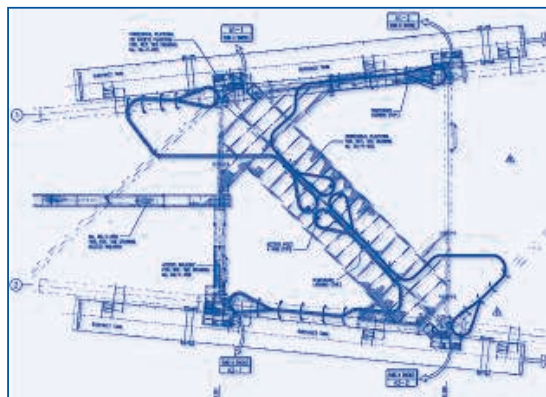

# ADDING MO

## Franklin Database Management System

The Franklin Database Management System is a powerful database that records equipment details and inspection information. It allows all relevant documentation to be accessed 24/7.

Documentation includes:

- Original test certificate
- NDT/ MPI reports
- Multimedia attachment of photographs, videos
- Inspection history
- Inspection criteria
- Name and qualifications of the inspector



The Franklin Database Management System is a powerful tool in an environment of more stringent regulations and increased scrutiny

## Benefits of the Franklin Database Management System

The benefits include:

- Fully-auditable quality control system for inspection of supplied services
- Compliance with legislation
- Independent verification of equipment inspections and certifications
- Provides a clear and auditable trail for regulatory audits
- Access to details of all equipment
- Traceability of each item and inspection history
- Out-of-office remote access to data 24/7



# REVALUE

## Offshore Construction Barges Hoist Rope Inspections

### E-mag Steel Wire Rope Inspection

Steel wire ropes are used in many hoist-type applications, and for various reasons, wire ropes are subject to damage, wear, corrosion, and defects that cannot be identified with an external visual inspection.

The E-mag rope inspection method has many benefits that include:

1. The steel wire rope does not need to be cleaned or have lubricants removed
2. E-mag identifies Loss of Metallic cross-sectional Area (LMA) defects and the location on the steel wire rope
3. E-mag identifies wire breakage defects, called Local Faults (LF)

These types of damage can occur anywhere on the surface or internally within the rope.

---

### E- Mag Rope Inspection Software

Our technicians and inspectors have all been specially trained to review and correctly interpret the information that the software generates. Complete data is collected for each and every rope that we inspect and form part of the comprehensive rope inspection reports that are issued.



Calibration E- Mag unit on test rope



# ALWAYS

## Cable Laid Sling Inspections

Based on the international standards and guidance notes, all cable laid slings should be thoroughly inspected prior to use. With many years of experience, we can carry out these inspections and issue the inspection reports.



Onsite Cable Laid Inspection Services

### Inspection Work Method

Our inspection procedures comply with IMCA M 179 Guidance on Use of Cable Laid Slings and Grommets



Load Testing of Cable Laid Slings



Inspection of Sling Saver Shackles

# READY

## Green Pin Sling Saver Shackles

### Van Beest Green Pin Shackles

Shackle Code: P-6033 Sling Saver Shackle

Material: Bow and pin alloy steel, Grade 8, quenched and tempered

Safety Factor: MBL equals 5 x WLL

Finish: Shackle bow painted silver, pin painted green

Temperature Range: -20°C to +200°C

Certificates: Lloyd's Register of Shipping Certificate on proof load, Mill Certificate MPI Inspection Report

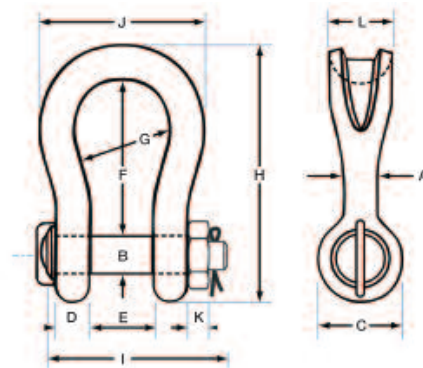

WLL tonnes	Dia. Body	Dia. Pin	Dia. Eye	Width Eye	Width Inside	Length inside	Width Bow	Length	Width	Width	Nut Thickness	Bearing Surface	Weight Each
	A	B	C	D	E	F	G	H	I	J	K	L	Kg
55	60	57	115	55	95	250	160	396	304	270	45	100	50
75	70	70	140	70	105	290	186	467	359	345	54	120	67
125	85	80	155	85	130	365	220	569	428	410	64	150	110
150	94	95	180	89	140	390	250	627	441	455	50	170	160
200	110	105	200	100	150	480	276	744	474	508	50	205	220
250	126	120	228	110	170	540	300	842	528	600	60	240	320
300	135	134	245	122	185	600	350	926	594	620	70	265	350
400	160	160	295	145	220	575	370	964	686	715	80	320	635
500	170	180	330	160	250	680	450	1107	763	810	90	340	803
600	190	200	350	170	275	740	490	1207	828	913	100	370	980
700	200	215	392	190	300	750	540	1257	878	993	100	400	1260
800	218	230	420	200	325	850	554	1395	959	986	110	420	1430
900	242	255	466	220	350	850	584	1454	1040	1050	120	440	1650
1000	260	270	490	240	380	855	614	1497	1116	1176	120	460	2120
1250	285	300	510	260	430	930	650	1620	1193	1275	150	530	2400
1500	295	320	550	280	460	950	680	1710	1278	1350	160	580	2980

Note: +5% forging tolerance on inside width and length

# GLOBAL REACH

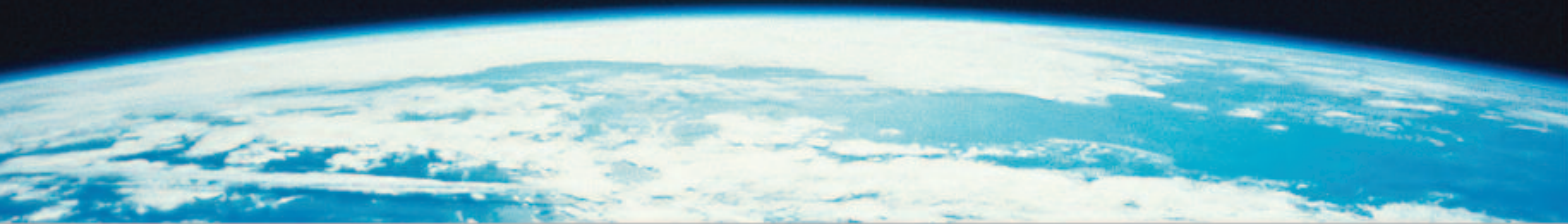

#### Corporate Headquarters

**Franklin Offshore Holdings Pte. Ltd.**  
11 Pandan Road  
Singapore 609259  
Tel: +65 6264 3451  
Fax: +65 6264 1130  
Email: [general@franklin.com.sg](mailto:general@franklin.com.sg)

#### Our Franklin Offshore Group of Companies:

**Franklin Offshore International Pte. Ltd.**  
11 Pandan Road  
Singapore 609259  
Tel: +65 6264 3451  
Fax: +65 6264 1130  
Email: [general@franklin.com.sg](mailto:general@franklin.com.sg)

#### Marine and Logistics Support Base

10 Pioneer Sector 1  
Singapore 628444  
Tel: +65 6863 1110  
Fax: +65 6863 4881  
Email: [general@franklin.com.sg](mailto:general@franklin.com.sg)

#### Franklin Offshore Caspian Ltd.

Salyan Highway, 15th km  
Baku AZ - 1023  
Azerbaijan  
Tel: +994 12 447 4071  
Fax: +994 12 447 4076  
Email: [office@franklin.baku.az](mailto:office@franklin.baku.az)

#### Cajun MMC Pte. Ltd.

11 Pandan Road  
Singapore 609259  
Tel: +65 6264 3451  
Fax: +65 6264 1130  
Email: [general@cajun.com.sg](mailto:general@cajun.com.sg)

#### Franklin Offshore Americas, Inc.

1325 South Creek Drive, Suite 850  
Houston, Texas 77084 U.S.A.  
Tel: +1 281 578 3828  
Fax: +1 281 578 2938  
Email: [general@franklinamericas.com](mailto:general@franklinamericas.com)

#### CFE Engineers Asia Pte. Ltd.

10 Pioneer Sector 1  
Singapore 628444  
Tel: +65 6861 6006  
Fax: +65 6863 6106  
Email: [general@cfengineers.com.sg](mailto:general@cfengineers.com.sg)

#### Franklin Offshore Korea Co., Ltd.

# 1203-6 Jisa-Dong, Gangseo-gu  
Busan, South Korea 618-230  
Tel: +82 51 832 0156/7  
Fax: +82 51 832 0158  
Email: [franklin@franklinkorea.com](mailto:franklin@franklinkorea.com)

#### PT Franklin Offshore Indonesia Perkasa

Jalan Mulawarman 48 Rt. 038  
Kelurahan Manggar  
Kecamatan Balikpapan Timur  
Balikpapan 76116  
Kalimantan Timur, Indonesia  
Tel: +62 542 743668  
Fax: +62 542 743688  
Email: [general@franklinindonesia.com](mailto:general@franklinindonesia.com)

#### Jakarta (Office)

Sona Topas Tower, Suite 15A#88  
Jl. Jend. Sudirman Kav. 26  
Jakarta 12920, Indonesia  
Tel: +62 21 5297 1958/59  
Fax: +62 21 5297 1956  
Email: [general@franklinindonesia.com](mailto:general@franklinindonesia.com)

#### Franklin Offshore Australia Pty. Ltd.

Perth (Head Office)  
10 Sparks Road  
Henderson, WA 6166  
Australia  
Tel: +61 8 9410 2480  
Fax: +61 8 9437 1126  
Email: [sales@franklinoffshore.com.au](mailto:sales@franklinoffshore.com.au)

#### Dampier

#### (Operating Base)

BIS Industrial  
King Bay Road  
Dampier WA 6713  
Australia  
Tel: +61 8 9185 6056  
Fax: +61 8 9185 6014  
Email: [dampiersales@franklinoffshore.com.au](mailto:dampiersales@franklinoffshore.com.au)

#### Darwin

#### (Operating Base)

4 Cochrane Road, Berrimah  
Darwin NT 0828, Australia  
Tel: +61 8 8947 3777  
Fax: +61 8 8947 3700  
Email: [darwinsales@franklinoffshore.com.au](mailto:darwinsales@franklinoffshore.com.au)

#### Energy Equipment Services Pte. Ltd.

11 Pandan Road  
Singapore 609259  
Tel: +65 6266 8786  
Fax: +65 6266 8780  
Email: [general@eesvc.com.sg](mailto:general@eesvc.com.sg)

#### Franklin Offshore Qatar W.L.L.

Street 45, Gate 44  
Salwa Industrial Area  
PO Box 32297  
Doha, Qatar  
Tel: +974 4450 0338  
Fax: +974 4450 0339  
Email: [general@franklinqatar.com](mailto:general@franklinqatar.com)

#### Franklin Offshore Europe B.V.

Pieter Zeemanweg 200  
3316 GZ Dordrecht  
The Netherlands  
Tel: +31 (0) 78 618 78 77  
Fax: +31 (0) 78 617 00 53  
Email: [info@franklineurope.nl](mailto:info@franklineurope.nl)



**FRANKLIN OFFSHORE**

[WWW.FRANKLIN.COM.SG](http://WWW.FRANKLIN.COM.SG)